

## Introduction

With any Real Time Clock, there needs to be a quartz crystal controlling the oscillator frequency. This is necessary because variations of even 20 parts per million in the oscillator frequency result in a clock that is off by almost a minute a month. Typically, this oscillator consists of an inverting amplifier and a 32.768kHz crystal network. The constraints on this oscillator circuit are many. The Oscillator should:

- be simple
- oscillate at the desired frequency and not vary in frequency over voltage or temperature
- readily oscillate on application of power at any operating voltage and temperature
- be a “clean” oscillation with no instabilities that can be interpreted as extra clocks
- not consume much current

Often, meeting one requirement makes it harder to meet another. This application note looks at the Intersil Real Time Clock oscillator circuit and examines the network requirements for maximum coverage of the desired features.

## Oscillator Accuracy

The real time clock operates at 32.768kHz because this frequency divided by  $2^{15}$  equals one clock per second. The oscillator accuracy depends primarily on providing the proper capacitive load to the crystal oscillator element. A typical quartz crystal oscillator is the CFS-206 from Citizen. This crystal expects a 12.5pF load for operation at exactly 32.768kHz. If the load varies, the oscillator frequency varies. This relationship is shown graphically in Figure 1.

Problems arise when process variations or component tolerances change the capacitive loading, hence affecting frequency accuracy. Since this oscillator provides the timebase for the real time clock counters, any variations in frequency translates into inaccuracies in the measurement of the real time. Intersil’s first Real Time Clock makes use of external components to allow adjustments for greater accuracy.

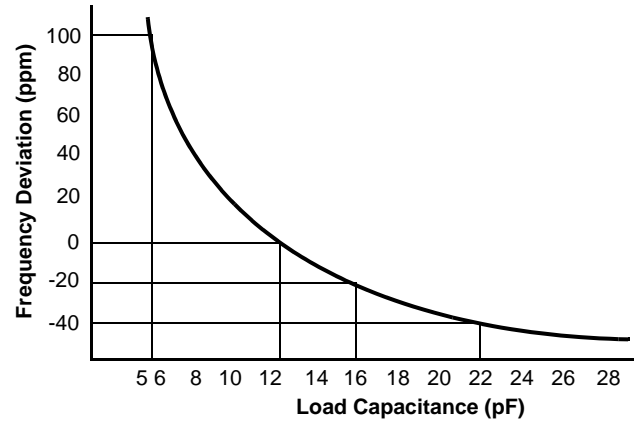

FIGURE 1. Frequency Accuracy vs. Load Capacitance

## Oscillator Network

The Intersil Real Time Clock requires the use of two external resistors and two external capacitors in addition to the crystal itself (See Figure 2.) The resistors set the level of feedback in the oscillator circuit. The capacitors adjust the loading on the crystal for both stability of the oscillator and proper loading of the crystal element.

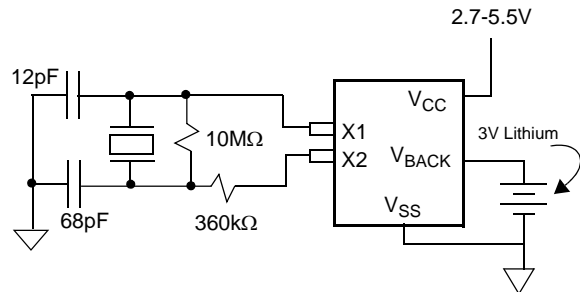

FIGURE 2. RTC Oscillator Network and Power Supply

For the circuit of Figure 2, the crystal sees the loading of the two capacitors in series. This is represented as:

$$\frac{1}{C_{tot}} = \frac{1}{C_1} + \frac{1}{C_2}$$

where  $C_1 = 18\text{pF}$  and  $C_2 = 43\text{pF}$ . This works out to a loading of 12.7pF. Similar loading is achieved with  $C_1 = 18\text{pF}$  and  $C_2 = 39\text{pF}$  (12.31pF) or  $C_1 = 16\text{pF}$  and  $C_2 = 56\text{pF}$  (12.4pF). A 12.5pF load capacitance yields an expected error of about 0 ppm

## Operating Conditions

The Intersil Real Time Clock is functional over an industrial temperature range (-40°C to +85°C). The crystal in an external network, however, typically operates over a much narrower range. Seiko specifies that their crystal operates from -10°C to +60°C. Also, as the temperature varies from 25°C, the accuracy of the crystal degrades. Figure 3 shows a frequency-temperature curve for the Seiko VT-200.

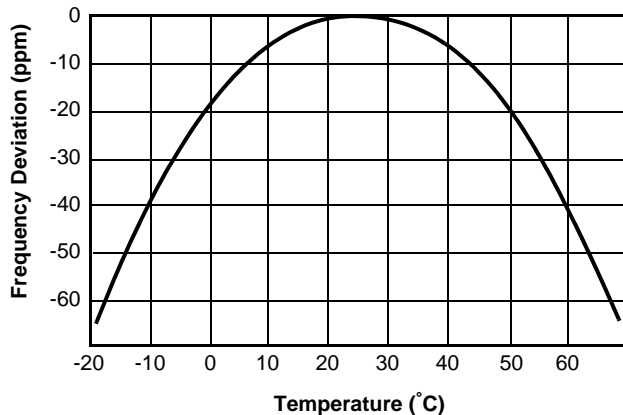

FIGURE 3. Crystal Frequency-Temperature Curve

This curve shows that changing the temperature by plus or minus 20°C results in a 10ppm reduction in the frequency of the crystal (and a comparable error in the real time clock reading.) In order to “widen” the temperature range over which there is less than 10ppm change in frequency, the values of the capacitors in the external network can be changed. For example, the capacitors can be chosen to give a +10 ppm error at 25°C. This will effectively shift the curve up, so instead of +/-10ppm from 7°C to 43°C, there is an accuracy of +/-10ppm from 0°C to 50°C.

## RTC Oscillator Characterization

Characterization of the Intersil Real Time Clock indicates that the oscillator frequency changes over temperature with a curve similar to that of the crystal, though the temperature impact is not as great in the circuit as with an individual crystal. There is also a variation in frequency that is dependent on the operating voltage applied to the device. This variation is much less significant than the temperature and is linear with respect to voltage. Characteristic curves over temperature (0°C to 60°C) and voltage are shown in Figure 4.

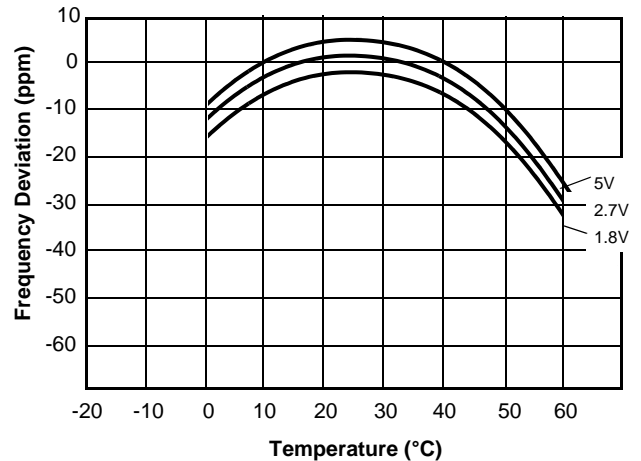

FIGURE 4. RTC Oscillator Frequency vs. Temperature and Voltage

An alternative to using an external crystal and network is the use of an external temperature controlled crystal oscillator (TCXO) module. This is typically used in an application that requires operation over an industrial temperature range or more accuracy over temperature. TCXOs are highly accurate and consume little current.

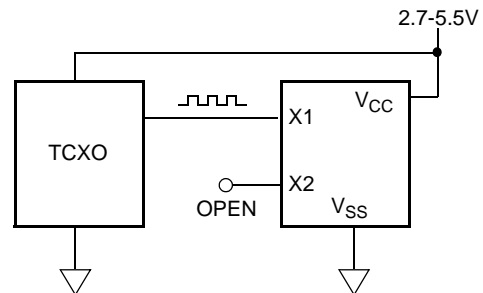
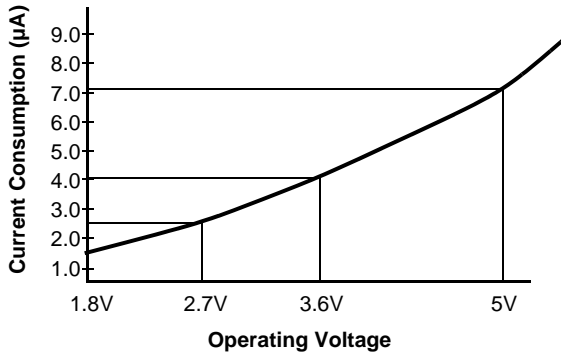

FIGURE 5. RTC Wiring TCXO

## Current Consumption

The current consumption of the real time clock circuit can be an important consideration in the design of a system. The Intersil Real Time Clock device itself consumes very little current. When driven by an external 32.768kHz oscillator the RTC draws less than 1µA from the supply source. When using the external network, however, the current consumption is somewhat higher. This current consumption is greatly dependant on the power supply voltage and not by the temperature. The curves in Figure 6 show typical current consumption over operating voltage.



**FIGURE 6. Current Consumption vs. Operating Voltage (recommended external crystal network)**

In a typical application (See Figure 2), the main system supply connects to  $V_{CC}$  and a primary (non-rechargeable) battery connects to  $V_{BACK}$ . When  $V_{CC}$  is greater than  $V_{BACK}$ , an internal switch from the battery is open and no current flows out of the battery. When  $V_{CC}$  fails, the real time clock circuits automatically connect to the backup supply source. A common backup battery is a Lithium type that provides between 3V and 2V. An Energizer CR2032 Lithium battery provides 225mAh (from 3V down to 2V) and would maintain the time and date in the Intersil RTC for a cumulative 10 years of main power failure.

Alternatively, a supercapacitor can be used to provide voltage to the clock during main power failures. A supercap can provide several days of operation during a power outage and does not pose the environmental or manufacturing problems of lithium batteries. Since the capacitor needs to be charged, an external diode is required in the circuit as shown in Figure 7.

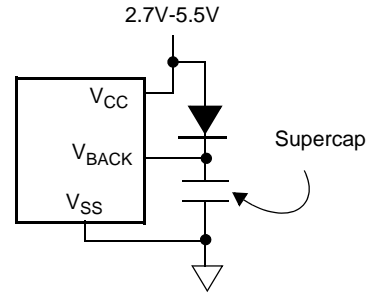

**FIGURE 7. Use of a supercap for  $V_{BACK}$**   
 Supercaps are available with capacities to 1F and above. Using a standard capacitor discharge equation, with the following assumptions, Table 8 shows maximum duration of a power outage that various supercaps can maintain the RTC. This capability is often all that is required.

$$i = C \frac{dV}{dt}$$

$$dV = 4.3V \text{ to } 1.8V$$

$$i = 3.5\mu A \text{ (average current from 4.3V to 1.8V)}$$

**Table 1. RTC operating time using a SuperCap**

Capacitance	Power Outage Duration	Capacitor Physical Size*
0.1F	0.8 days	12.5mm diameter, 5.5mm height
0.22F	1.8 days	
0.47F	3.9 days	20mm diameter, 6mm height
1.0F	8.3 days	

\* Panasonic SG series Gold Capacitors

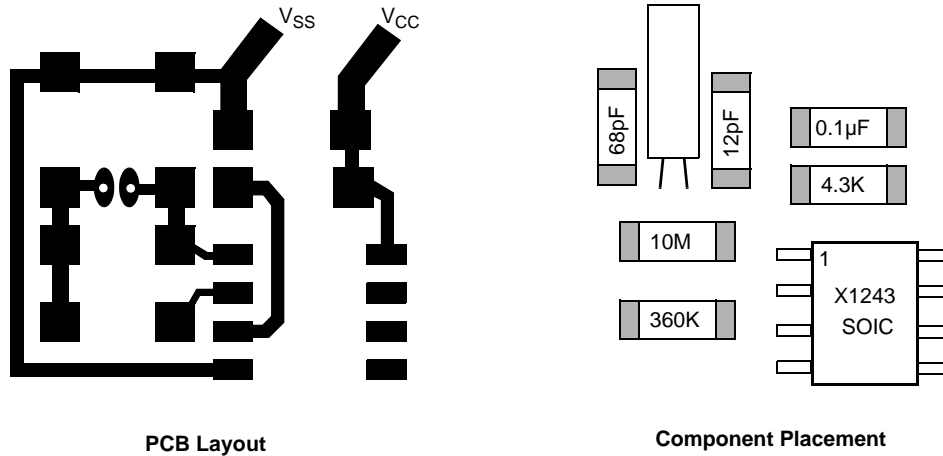

FIGURE 8. PCB Layout for X1243

### Board Layout

While Intersil's Real Time Clock is less sensitive to board layout than some clocks, there is still reason to be cautious in the layout of the external components. The problem exists because the internal threshold levels on the X1 input are necessarily narrow. Noise on the X1 pin can therefore cause oscillations as the input comparator tries to track the noise. These oscillations are perceived as additional clocks, and the RTC appears to run fast. While there are many ways to implement this layout, one suggestion is provided in Figure 9. This layout includes a bypass capacitor from V<sub>CC</sub> to V<sub>SS</sub> and a pull-up resistor (4.3kΩ) on the IRQ output. Pull up resistors on the SDA and SCL lines are not included.

### Summary

Although the Intersil Real Time Clock integrates a clock calendar, alarm, battery backup circuit, EEPROM and (in some versions) a CPU Supervisor into a single package, the primary role of this device is to maintain the real time. To do this, a crystal controlled oscillator provides an accurate timebase. By using external components, this oscillator achieves better than +/- 30 seconds a month accuracy over 0°C to 50°C and consumes so little current the clock operates for up to 10 years from a single lithium battery.

Intersil Corporation reserves the right to make changes in circuit design, software and/or specifications at any time without notice. Accordingly, the reader is cautioned to verify that the Application Note or Technical Brief is current before proceeding.